

Saxophone and Clarinet Fundamentals



Chuck Currie
Sax Noir Studio
www.saxnoir.com
reedguy@telus.net
604 970 2694

Table of Contents

| | |
|---|-----------|
| 1. Breathing and Open Throat | 3 |
| 2. Air Flow “Prompts” | 7 |
| 3. Reed and Mouthpiece | 7 |
| 4. Reed Placement | 8 |
| 5. Embouchure Placement | 9 |
| 6. Saxophone Embouchure | 11 |
| 7. Clarinet Embouchure | 12 |
| 8. Buzzing the Mouthpiece | 13 |
| 9. Long Tones | 14 |
| 10. Tonguing and Expression | 15 |
| 11. Tongue Placement | 16 |
| 12. Legato (or Portato) Tonguing | 16 |
| 13. Staccato Tonguing | 17 |
| 14. Dynamics | 19 |
| 15. Smart Practice Techniques | 20 |
| 16. Practice And Lesson Routine | 21 |
| 17. Advancing Development | 21 |
| 18. Tongue Position For Higher Pitches (Saxophone) | 22 |
| 19. Fingers | 22 |
| 20. Instrument Care | 23 |
| 21. The Tone - Articulation Pyramid: a review | 25 |
| | |
| Appendix 1: Mouthpiece Terminology | 26 |
| Appendix 2: TEMPO AND OTHER MARKINGS | 28 |
| Tempo | |
| Metronomes and beats per minute | |
| Common qualifiers | |
| Mood markings with a tempo connotation | |
| Terms for change in tempo | |
| French tempo markings | |
| German tempo markings | |

1. Breathing and Open Throat

The player and the horn are a wind machine from the bottom of the abdomen to the end of the bell of the instrument and then on to the very back of the hall. One needs to have plenty of wind to start with, so one has to learn how to breathe more deeply than most people do in normal life.

- One breathes the most deeply in normal circumstances when one is yawning. The body first tries to get rid of excess carbon dioxide by exhaling more fully than usual. This is where the “sound” of yawning comes from—the incredibly complete exhale. Try it—pretend you are really sleepy or just had a huge Thanksgiving dinner in a stuffy room. **Yawn** out really completely...get rid of all your air. This has the added benefit of opening your throat fully, which is critical for a good full warm sound.
- Now, this is when you should inhale more air than usual. Let’s accentuate that. Loosen your belt and try not to wear tight pants when you are playing. Sit up straight but not rigid. Don’t let your back touch the chair. Totally relax your shoulders. Let your arms dangle from your shoulders. Let your head “dangle” up from the top of your neck like it is a balloon filled with helium.
- Now **pull** the air really deep into your body, way down in your belly. You should try to push your belt buckle way out towards the wall opposite you. Pretend you are about to blow up a really big balloon and suck the air in fully and deeply with a fully open throat. Get the feel of a really open throat by whispering “ahhhhhhhh.”
- One way to be sure you are really breathing good and deep and filling up totally with air is to lie on your back and place a heavy book over your belt or your belly button. Try and push the book way up to the ceiling. Remember to yawn out the air first—this will relax your throat and air passages and allow you to really breathe in fully. You should notice when you do this that not just your tummy expands. Your sides and your back expand too, just not quite as much. This is why you should sit up straight when playing and not let your back touch the chair—you cramp your breathing a little bit.

There are many methods to enhance breath and airflow, but the simplest two are the use of a 2" X 1" piece of PVC piping and a 12" balloon.



The **PVC piping** aids in “pulling” the air deeply down into the lungs, meanwhile opening the throat really wide. The clarinet barrel works equally well, but is not really practical unless the player has multiple barrels. Simply place the lips around the entire piece of piping and breathe in and out deeply.





Note that when one breathes in deeply and quickly using the PVC piping the air seems to automatically fill one from the top of the abdomen upwards, and the inhalation is very quick indeed. This quick intake of air in one beat is ideal for cueing entrances in chamber music. Count time mentally before starting a piece of music and then take an exact one beat intake of air. This will help all players' time feel (especially if they are counting in mentally with sub-divided beats to rhythmically complex entrances.)

Example: one-e-and-a, two-e-and-a, three-e-and-a, BREATHE.

Once a player is used to this feeling, one simply tries to keep that feeling in the throat at all times. In the early stages of keeping tension out of the throat, one should return to the PVC pipe frequently.

There are two schools of thought about the concept of "open throat" for clarinetists. Some teachers believe an open throat is incompatible with the high tongue that is essential for a mature brilliant clarinet sound from cold, fast air. However, if one says the word "hawwww" and keeps that feeling of the open throat low tongue at the back of the oral cavity, and then say "eeeeee" which raises the center and front of the tongue, one can combine the open throat with the high tongue position.



Watch anyone breathe in just before they attempt to blow up a **balloon**, and it is easy to see how much more deeply they pull their breath into their lungs than normal. Use a 12” balloon, they provide lots of resistance. One should try to blow the balloon up as **fully and quickly as possible**. Always reinforce the concept of pulling the air very deeply into the bottom of the tummy. This is anatomically impossible, of course, but coaching in these terms works. The player should think of their belly button pushing out. A sign of shallow or “top of lung” breathing are shoulders rising early in the intake of air. Coach players to “commit to the air.” It is worth interrupting them before they even start to blow if you see and hear that they are not committed to a full, deep inhalation through a very open throat.



2. Air Flow “Prompts”

“When you breathe in, try to empty the room of air....don’t leave any for anyone else. Suffocate them, and then blow them all out of the room.”

“Loosen your belt and push your belly button out to breathe in deeply and fully.”

“Breathe like Darth Vader!”

3. Reed and Mouthpiece

- a. Your reed and mouthpiece setup is the most important part of your instrument. You need a nice flat “table” on your mouthpiece with a really smooth reed sealing it. A medium reed on a medium mouthpiece is the best for most people, especially students. Keep your mouthpiece nice and clean by washing it in lukewarm water with a drop of dish soap and a soft cloth every week. If you see white buildup (calcium) anywhere on or inside the mouthpiece, soak it for 5 minutes in half vinegar/half water. I recommend a thin mouthpiece patch to stop your teeth vibrating when playing and ensure the embouchure is secure without having to bite.
- b. You need 600 grit wet/dry sandpaper and a piece of glass about 3 ½ inches by 7 inches by ¼” thick. Use #2 ½ Rico Royal reeds for beginners and then to #3 for the next box. Once you stop breaking reeds by accident, immediately move to premium reeds such as Vandoren or Rico Reserve or Légère.
- c. Test multiple reeds when selecting your reeds. Mark the reeds with numbers up near where the “bark” is cut, so that you can tell them apart. They should not seem too hard or too soft and should vibrate and “speak” well on high and on low notes. Try long tones, portato and staccato tonguing on high and low notes, and play at least a two octave scale listening to tone color and feeling the resistance.
- d. New reeds sound a little “raw,” until they are seasoned with the following procedures. Soak new reeds well with water. Dry the back of them and sand them on the sandpaper until they are nice and smooth. Do this 3 days in a row with new reeds, and only play them 10 minutes or so. The reeds will as smooth as glass after this treatment. The first day, also sand the front of the reed just where your lip will touch them to make it feel nice and smooth. You only have to do this once. The reeds will also season much faster if you place them on a piece of glass after playing, and rub out the excess moisture with your thumb or finger, rubbing from the stock of the reed down to the tip. This only needs to be done the first 3 days.

You may need to sand the back of the reeds again after a few weeks play if they feel rough to the finger tip again. A well seasoned reed sounds more polished, articulates cleanly, and lasts longer than a reed that has not been seasoned.

- e. Play all three reeds at least once or twice per week, not just your favorite one. That way they will all keep developing and you will have spares that work well when your favorite is worn out or breaks. Play your favorite about 75% of the time and the other the remainder. As your favorite gets a little old and weaker, you will be able to tell because your backup reeds are still fresher and springier. You will be able to clip the tip off your primary reed once towards the end of its life to refresh it, but be ready to give it up as it gets “flabby.” Do not get used to one “good reed.” It will become progressively weaker and so will your lip muscles. All subsequently used reeds of the same strength will seem too hard.
- f. Keep your reeds in a “reed guard” or a glass cushioned case or place them on your piece of glass and hold them on with a thick rubber band.

4. Reed Placement

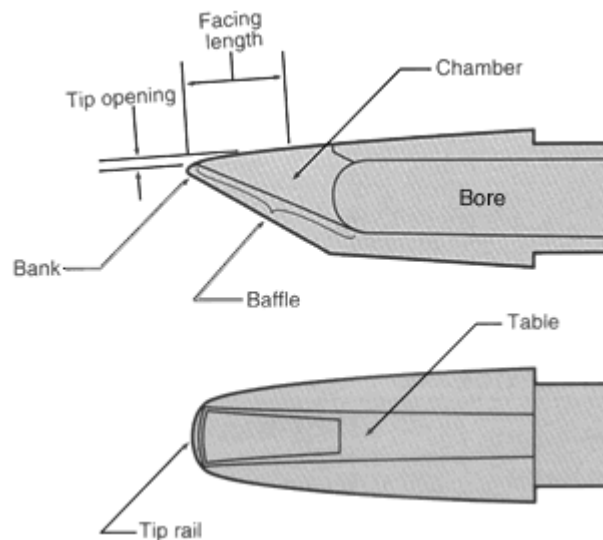

Table: the flat surface upon which the reed is placed.

Window: the hole in the mouthpiece between the tip rail and table.

Side rails: the side edges of the window.

Baffle: the roof of the mouthpiece chamber.

A good quality clean mouthpiece with no dirt, abrasions or chips on the table or the tip or side rails is critical to response. The reed must be placed exactly even

with the tip and side rails for good tone quality and precise articulation. No serious player ever just slaps a reed on to a mouthpiece without great care.

The ligature must be snug, not too loose or tight. You should not be able to move the reed by pushing it from the side, but it must not be clamped so hard that the vibrations will be dampened. The top of the ligature or any plate or rail touching the stock of the reed should be approximately $1/8^{\text{th}}$ " or 3 mm below the first cut of the reed. Higher and it will dampen vibrations, lower and it will allow air leakage onto the table and make articulation a little more difficult.

5. Embouchure Placement

Along with not breathing deeply enough and using a closed throat, the most common error in single reed playing is not taking enough mouthpiece. The bottom lip over the teeth should touch the reed at the "control point," where the facing curve flattens out and goes straight towards the table. This is the point at which the table of the reed meets the side rails of the mouthpiece. If one takes less mouthpiece than this, the reed's vibration is compromised and the instrument will also play sharper. If one's embouchure is lower down on the reed, below the control point, the tone will be "honky" and out of control, not refined at all. It is very common for players to take less mouthpiece when they move up to a harder reed or a more open mouthpiece...it gives them more of a feeling of control and they are basically negating the effect of the stronger reed or more open mouthpiece.

Here is the control point of a mouthpiece. The .0015" thick stainless steel shim is visible behind the Lomax facing curve measuring gauge. This particular soprano clarinet mouthpiece has a facing curve of 17 mm (since the numbers represent 2 mm measures.) This is a medium facing curve by current clarinet mouthpiece standards.

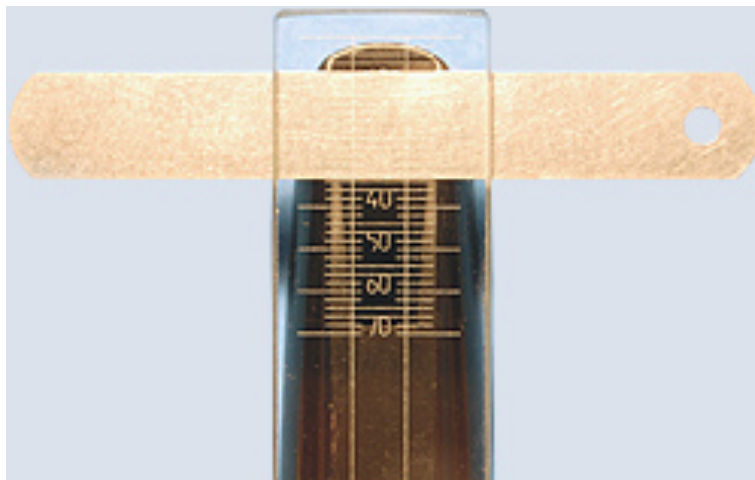

To determine the contact point of a mouthpiece, place a reed correctly on the mouthpiece, and place a thin piece of paper (unless you have one of these fancy shims!) between the side rails and the reed table.



Then mark a pencil line across the center of the reed $1/16^{\text{th}}$ inch or 1 mm below the paper. This small increment allows for the thickness of the lower lip over the teeth so that the lip is directly on the contact point when the mouthpiece is placed in the embouchure.

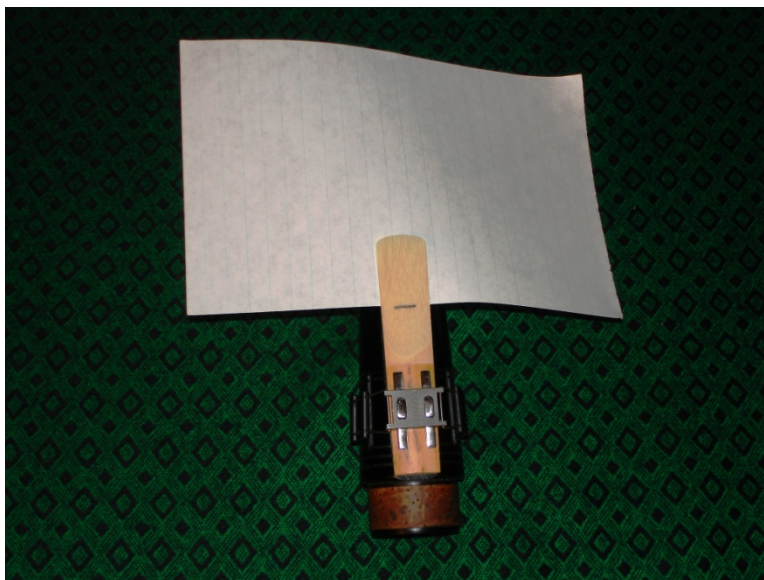

Now when buzzing the mouthpiece to develop air flow, flexibility of embouchure and articulation, one places a thumbnail on the pencil mark and inserts the mouthpiece into the embouchure so that the thumbnail bumps right into the lower lip before blowing.

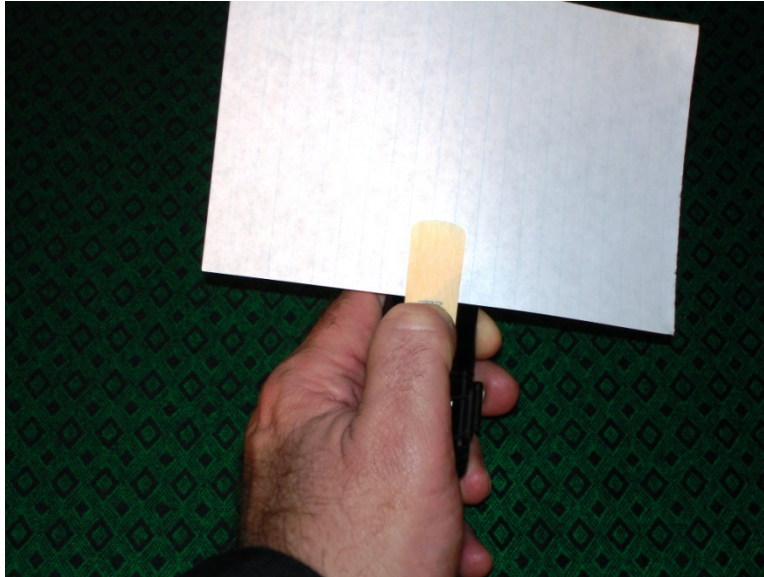

6. Saxophone Embouchure

The bottom lip is just folded over the bottom teeth. The top teeth and lips are placed gently on the mouthpiece, with the teeth bearing the weight of the head, but not fully, since one's head should have the feeling of floating a bit. Think of the lips like a rubber band stretched evenly and gently all around the mouthpiece. The sides of the lips are pulled in snug, but the top teeth and the bottom lip and teeth just rest on the reed and mouthpiece with no biting at all, just a tiny bit of snugness like a loose thick rubber band. If you can form your lips into a "whistling" shape this will give you a nice snug, round relaxed embouchure.

Think of your bottom lip like a "hammock" or a canvas "swing seat" supported by the corners of your lips. It is form fitted to the reed but does not "press" into it, just supports it comfortably.

All the pressure on a mouthpiece and reed should come from the sides, NOT the top and bottom. If one produces the vowels "oooooooo" (as in "loop") and "eeeeeeee" alternately, trying to stretch the lips in as far as possible on "oooo" and out as far as possible on "eeee," one can quickly feel how these important "side" muscles tire. They need to be very well developed indeed in order to produce a beautiful contained warm sound. Instead, we tend to use our powerful "up and down" chomping muscles! Development of these side muscles is exactly why we play long tones.

The majority of players bite; and many bite *incredibly hard* on the reed. The jaw muscles are amongst the very strongest muscles in the body and it is in our nature to bite anything we insert between our teeth! When there is not enough mouthpiece and reed in the embouchure the result is a dull, timid, sound and it is very difficult to articulate, as the reed vibration is incredibly dampened. This is what creates “hooting” clarinetists.

A thin plastic mouthpiece patch is almost essential in preventing this biting, as it gives some purchase for the upper teeth to the slippery surface of the top of mouthpiece with very little pressure. Once a player starts using one of these, usually it is unfathomable that one ever played without one. Thick, soft mouthpiece patches are not advised...they actually tend to make the player bite more rather than less.

7. Clarinet Embouchure

The above saxophone embouchure is recommended for all beginning clarinetists, and for more advanced clarinetists who tend to bite (*all* of them!) Once a full round open sound is developed on the instrument and the tendency to cramp and dampen the reed is overcome (which is quicker with beginners...four to six weeks, usually, while more experienced players can take months to overcome this habit), then one can apply the clarinet embouchure principals to this basic relaxed round embouchure.

The refined clarinet embouchure takes the full warm sound and “burnishes” it. It will be more resonant and focused and will project more. Think of the relaxed saxophone embouchure sound like an apple—round and warm. The refined clarinet embouchure is more pear shaped, it has a little more point on it, but is still round and warm.

Lower embouchure: the chin is pointed and pulls the lip downwards onto the bottom teeth; meanwhile you try to pull the lip back up over the teeth at the same time. This thins down the lip under the reed and allows it to vibrate more. The lip is pulled down with the chin and one thinks “ewwwcchhhh.”

Upper embouchure: The upper lip pulls in firmly against the teeth, like pulling a mask tight against your face. One should feel the “soft palate” the back part of the roof of your mouth raise up into an arch when you do this. Think “aaawwwccccchhhh.”

The two practices outlined above are what make almost every clarinetist bite like a junkyard dog. Teaching the basic saxophone embouchure first and establishing very light pressure from upper teeth and lower lip before adding the clarinet “mask” to the embouchure works wonders in developing a full warm sound before proceeding to the “burnishing” that produces a more ringing sound on the instrument.

Guard against tension in the embouchure. It is firm, elastic and flexible; not tight or tense. There is NO BITING or pressure from the lower lip or jaw against the reed.

The tongue is kept in a high position in the mouth while still maintaining an open throat. Say “hawwww” with the throat open and add “heeeeee” with the tongue, which will bring the center of the tongue up between the molars. This keeps the air speed fast and cold and gives ring and focus to the tone and keeps the pitch up on higher notes without having to firm the embouchure too much. The bass clarinet tongue position is lower, more like saying “hehhh.”

8. Buzzing the Mouthpiece

Now the mouthpiece is in the embouchure, or “chops.” One wants to learn how it feels to make the air vibrate in and flow through the mouthpiece. This is much more difficult than blowing an instrument and develops air flow, embouchure and articulation much faster than playing the instruments. It is like practicing with a 3 iron at the golf range...the 9 iron is SO easy to hit when you go back to it!

Some players have incredible difficulty with buzzing just the mouthpiece, and will need to add the clarinet barrel or the saxophone neck in order to do it at all. That is just fine, but eventually they should progress to buzzing the mouthpiece alone.

When one plays the instrument, the reed is “beating” against the rails and tip of the mouthpiece. It can beat as few as a hundred times per second on the low notes or as much as a couple of thousand times per second on the high notes, depending on which instrument one plays. The reason one is so careful about the reeds being smooth and flat and the mouthpiece being clean is so that the reed really seals against the mouthpiece as it beats. The reed spends 50% of its time in motion, 25% fully open and 25% fully closed.

Remember one is using a lot of abdominal pressure in blowing to project the sound. One’s abdomen is tense with muscular effort, but every other part of the body should be really relaxed: the head floats, the shoulders droop, the arms dangle, and the embouchure is not tense **at all**. (Once the mouthpiece is added to the horn and played the fingers just “drop” from the hands onto the keys.)

The mouthpiece enters the chops at the same angle it would be if it were on the instrument ready to play. Practice leaving the mouthpiece in there for breathing. Leave the teeth resting lightly on the top of the mouthpiece but everything else can open. The lips and bottom jaw open to breathe, but the top teeth stay in place. This way the chops always stay consistently in the same place when one needs to breathe while playing.

Relax the shoulders; pull tons of air deep into the abdomen, pushing out the bellybutton. Seal the chops around the mouthpiece snug but **do not bite**.

Now, **blow** a long, resonant projected buzz. Bounce it off the walls of the room.



Once there is a good loud long buzz, the pitch should be adjusted. Do not move the mouthpiece around to do this. Keep the lip corners pulled in snugly to the mouthpiece and move the jaw up and down slowly and smoothly. One should be able to make a sound kind of like a siren going up and down. If one only gets squawks, one probably has too much mouthpiece in the mouth. If one only gets very high notes or the reed pinches shut, one probably has not enough mouthpiece in your mouth.

Once the reed can be controlled up to really high and down to really low in pitch, one tries to just keep the pitch low. Just blow that low pitch from scratch. The low pitch gives the correct basic embouchure shape and quantity of mouthpiece in the chops for every note on the instrument. Practice this every time the instrument is put together and rapid progress will be made tone quality and projection.

There is a seemingly irresistible tendency to try for a low pitch and forget all about air pressure and making a projected loud long buzz when this process is started. This **will not work** without lots of air support. One should attempt to blow the stand over in front of one! Then, and only then, will the player be able to get the desired pitch. Teachers should get used to reminding players of their “commitment to air.”

9. Long Tones

Long tones should only be held until there is 25% of the air left. Full lungs make it easy to create support. The last 25% of air in the lungs will not give enough pressure for good tuning and tone. It's like driving up to Kelowna in the Rockies from Vancouver by the sea. The last gas station is about $\frac{3}{4}$ of the way there, but one still tanks up even if one has a half tank left....no fun running on fumes before you get to your destination!

One needs to play with increasing pressure through every long tone just to keep the same volume level. If one desires to play musically “through the phrase,” one has to ***really go for it!*** Increase the pressure dramatically all the way through the long tone and the tonguing exercises that follow, and the player will inevitably phrase better when playing music.



Now repeat all this on the instrument....low g for clarinet, low d for saxophone.

10. Tonguing and Expression

Tonguing gives music a more understandable message, just like punctuation in sentences makes conversation more understandable. A single long run-on sentence communicates very little. You need stops and pauses to communicate better.

- There are two basic kinds of tonguing. Staccato and portato. These relate to the period and the comma in a sentence. Staccato is a full stop, like the period at the end of a sentence. Portato is a brief interruption, like a comma.
- Both of these effects should be done with a very light tongue, so that you hear only the musical note, not the thudding of the tongue on the reed.

The Release: it is NOT an Attack.

- Do not think of the tongue starting the note. Air is what starts the note. The tip of the tongue does not have to touch the tip of the reed. The **top** of the tongue just above the tip is more comfortable and it can touch anywhere on the top ¼ inch of the reed and be perfectly effective. Say the word “doo” when you tongue and wherever your tongue feels comfortable touching the reed will work fine. “Doo” also helps you keep a round snug embouchure that helps you refrain from “biting” the reed.
- The air is **always going** when you tongue. It is the tongue **lightly** stopping the reed from vibrating that stops the note. If you keep the air going all the time, and just **release** the tongue from the reed, then the notes pop out quickly with a full tone.

11. Tongue Placement

Ensure the player starts the note with a clean soft `dah` and finishes the long tone by placing the tongue on the reed before any lessening of air. Finish as if running full tilt boogie into a brick wall, like Luciano Pavarotti on the ultimate high note of an aria.

Tongue placement on the reed is NOT tip of the tongue to tip of the reed. Just say `dah` and place the tongue where it feels comfortable voicing that consonant and vowel. This will be the TOP of the tip of the tongue just BELOW the tip of the reed. The larger the instrument, the further down the reed

12. Legato (or Portato) Tonguing

Place the mouthpiece only in the mouth. Take a deep breath and blow good and hard. Now just touch the reed lightly with the tongue, saying the word “doo” very softly. The “ooo” vowel helps keeps the embouchure round. Touch the reed over and over again while keeping the air going good and strong. Now practice doing it evenly to a beat. It is best to play 8 long quarter notes and then end with a half note to a tempo of 82 beats per minute. This makes the notes long enough to seem like playing a long tone with gentle interruptions, but it is not so long that one runs short of air. The mouthpiece goes through air like crazy compared to an instrument...that is one of the great benefits of this exercise. It is important to ensure increasing pressure through this phrase to play it musically!

Some people have trouble keeping the air going while moving the tongue. In these cases, playing a long tone with **one** legato tongue placement in the middle can work very well. Then keep adding one more articulation in the middle of the long tone at a time until they are all connected beautifully with

no gaps in sound.

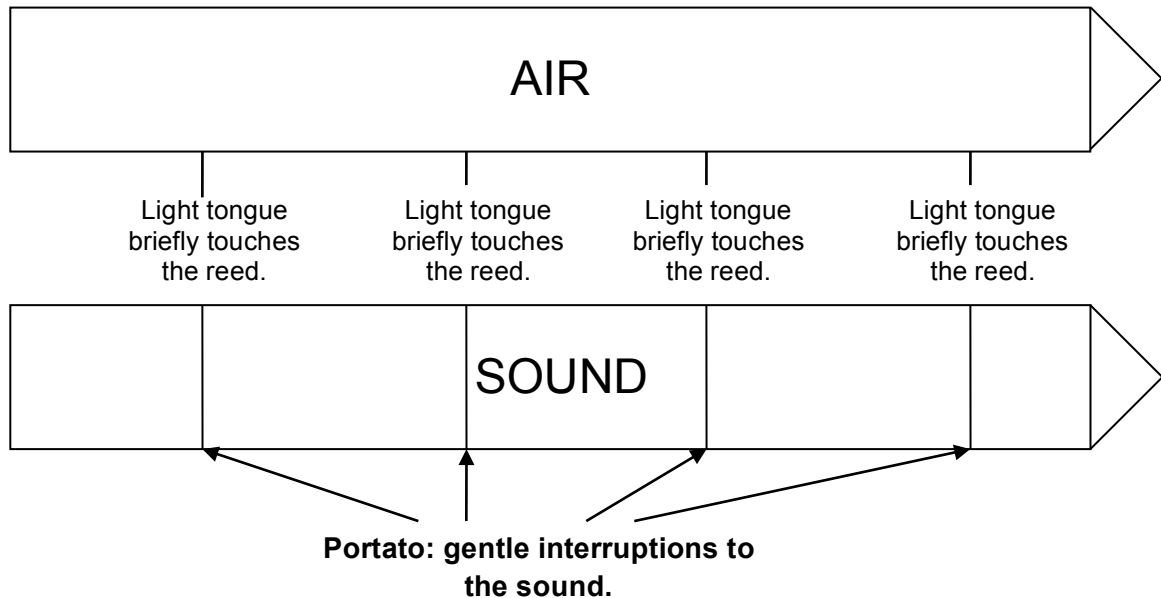

One will frequently hear the pitch going up while tonguing. The chin tends to move with the tongue. Players should watch their chin in the mirror while saying “la-la-la-la-la.” Then they say it while not allowing their chin to move. One will find that if one stills the back of the tongue and just uses the front of the tongue to repeat “la-la-la,” the chin will stop moving and this also makes tonguing more efficient while allowing for high tongue position for clarinet and variable tongue position for saxophone.

Now repeat all this on the instrument...low g for clarinet, low d for saxophone. These are the foundation notes for these instruments...all good tone color, articulation and dynamics are best learned here before moving up to higher notes or down to lower notes.

13. Staccato Tonguing

The tongue is placed lightly on the reed. Blow like mad. Put so little pressure on the reed that you still get a “dampened” tone. It will tickle the tongue like crazy. If just a tiny bit more tongue pressure is added air will go through the mouthpiece and maybe even escape a little from the corners of the mouth, but there will be no buzz. This is because the *very light* tongue will not let the reed vibrate. Practice taking the tongue off and putting it back on again very quickly. Leave it on for a few seconds and then release and replace again very quickly. The consonant and vowel to use are “daht,” and the most important part is the “ah” in the middle so that that note has warmth and tone and is not just a

percussive tongue effect. The tongue is ***valve, not a hammer***. The tongue does not start the note....the AIR does. ***Remember to keep the air going!!***

Now the player plays two groups of staccato 16th notes at mm 82, finishing with a staccato 8th note. Once again, increasing pressure is necessary throughout the phrase. The air is like an arrow increasing in speed all the way to the last eighth note bulls-eye.

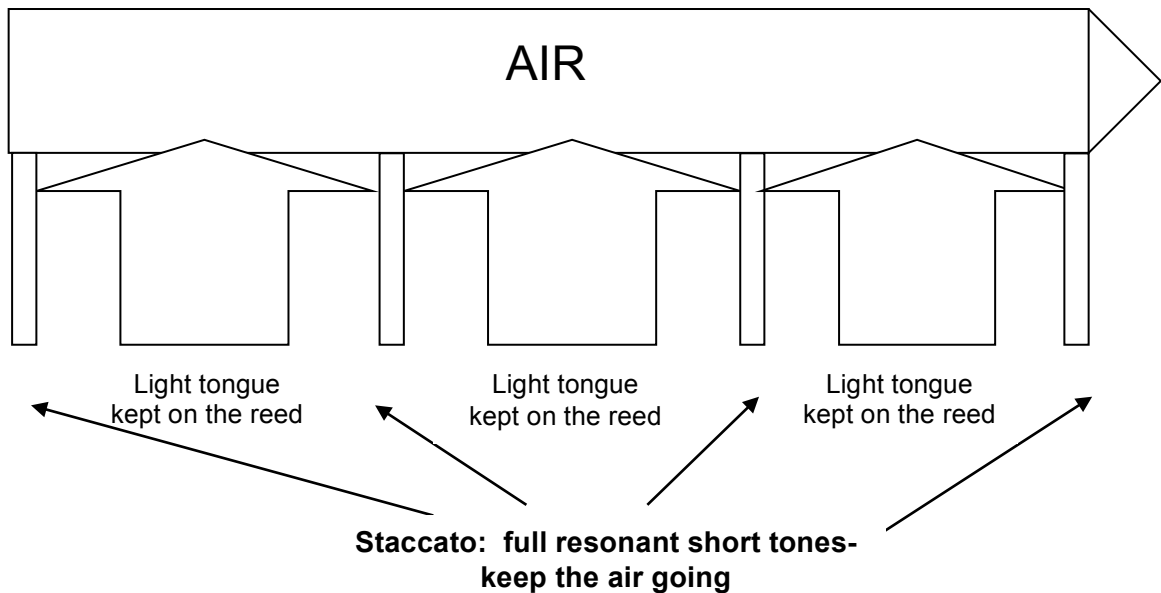

It is even more common for players to move their chin when tonguing staccato than legato and to have trouble keeping the air going while the tongue moves. The same two exercises help: play a long tone with one staccato note in the middle of it, then add more, ensuring there is no air stoppage between the notes. Repeat the la-la-la exercise to eradicate chin movement.

Another extremely effective exercise is to play a whole note long tone and then proceed immediately into 4 16th notes, followed without a gap by another whole note long tone. The stability of embouchure and air “on either side” of the staccatos facilitates the stability of embouchure and air through the staccatos.

Now repeat all this on the instrument....low g for clarinet, low d for saxophone.

For a good quality staccato, the mental and aural images should be “bouncy” and “crisp,” not “short” or “clipped.” “Daht” will give us a full warm tone in the middle and nice firm staccato. For a staccato with an attack, use “Taht” and for staccatissimo use “Tiht.”

14. Dynamics

Many players have a pretty good sound when they play *mf* and above, but have a progressively weaker and fuzzier tone as they play quieter. This is because they reduce air pressure to get quieter....it doesn't work that way...one actually needs **more** air pressure to play quietly.

The intuitive way to demonstrate this once a player has a good full warm tone all the time (which only takes a few weeks at most) is to have the player go back to the balloon. Instead of blowing the balloon up as quickly and fully as possible, we want to blow up the balloon as **s l o w l y** and fully as possible. The player must first blow the balloon up just past the initial very resistant stage (about 10% full) and then focus on blowing the balloon up infinitesimally bigger every second, just as slowly as possible. The best biofeedback on this is to have the player watch the balloon grow slowly, millimetre by millimetre.

This is incredibly hard work.

Now repeat all this on the instrument....low g for clarinet, low d for saxophone.

One will find the player can play a darn fine tone at very quiet levels. What this proves is that it is not lower pressure that emits a fine quiet tone, but **slowly moving air with a heck of a lot of support behind it!**

To teach the various levels of dynamics it is better to think of the numbers one through six than *pp* through *ff*. The player can think of six evenly incrementally louder tones more easily while the teacher holds up one more finger at a time. The player should first play the quietest beautiful note possible and then the loudest beautiful note possible. Emphasize **BEAUTIFUL!** If more players were drilled that *ff* is the most **BEAUTIFUL** loud note they can play brass players and saxophonists wouldn't get such a bad rap from the clarinetists, oboists, flutists, bassoonists and the poor desperate audience!

Once these softest and loudest **beautiful** notes' dynamic levels have been established, the player attempts to play six evenly louder and then softer long tones from 1 to 6 and back (or *pp* to *ff* and back.)

Every band practice should start with this exercise with each section in balance with the others to establish true *pp* and *ff* dynamics. It would go a long way towards emptying mezzo-band-land.

15. Smart Practice Techniques

- Make sure you know how fast the piece goes. You must have a metronome, you must practice with it **all the time**, and to make this effective you must ask your director what the *metronome marking* is. The metronome works by telling you how many beats there will be in a minute, for example MM 60 is sixty beats per minute or one per second.
- Ask your director about tempo. One, how fast does he want to take the piece in performance? Two, how fast is the tempo going to be when the band is just learning the piece? Mark these MM's on the music. You want to get it up to the "practice" tempo with clean articulation, a good sound and all the dynamics and expression **right away**. Then you work on getting it up to the minimum concert tempo, and eventually the ideal concert tempo. This will take a **disciplined effort**. Every musician in the world loves to play the stuff that s/he knows and sounds great-it makes you feel good and it is why you became a musician in the first place-to sound good. ***Real practice means you sound terrible because you are working on the stuff you find difficult.***
- First, play through the piece at a "doable" tempo. Not slow enough to play it perfectly: just slow enough to get it 90% right. The places you have problems with finger technique or rhythm or interval jumps/tuning/note response mark with a little pair of eyeglasses. These  little eyeglasses should not be thought of as "trouble" spots, think of them as places to "focus." Work on these places at **slow tempos** before you work on any other parts of the piece. Smart practice means **isolating** the smallest possible "focus" areas to the tiniest little "glitches" and drilling them over and over again very slowly, gradually increasing the tempo. Remember, concentration comes in small doses, so don't drive yourself crazy. Still...you have to discipline yourself to focus and listen hard for blurry notes or incorrect rhythms or unclear fingering or poor response and work on just those sections.
- Make sure you mark in all the breathing places in your music. Usually this is approximately every four bars, but it is not that mechanically simple. It has to follow the natural phrases.
- When you hit a difficult rhythm patch, take the horn out of your mouth and sing the rhythm (and melody, too) with the metronome until it is engrained and you won't have to think about it when you are blowing and fingering. Slowly, at first, then speed it up. Then slowly while blowing, then speed it up. Make sure you sing the dynamics and expression marks, too.

- Eventually, you will have the technical and rhythmic difficulties mastered. This is accomplished when you can just pick up the horn and play the whole piece perfectly, with and without the metronome. Remember, playing a “focus” section right after you have been drilling it isn’t the real goods. You’ve got to be able to do it “cold,” as part of the entire piece of music, just like a performance.
- If possible, get a recording of the piece and play along with it. Remember the whole point of this smart disciplined, practice was to play music *musically*. It doesn’t matter if it is a grade one piece or a concerto for your instrument. You are there to serve the music and play it with a beautiful sound and shape, even when your part is inner harmony or a bass line instead of the melody.

16. Practice And Lesson Routine

- Practice should mirror the lesson routine, or perhaps it is the other way around!
- Good steady progress cannot be made without routine practice and it is important to set aside regular times throughout the week devoted to this. Five 45 minute practice sessions per week is normally enough to advance very well, but more is even better. I have one student who plays four instruments and practices each of them an hour a day!
- A complete approach to the instrument involves 4 discrete areas of development in daily practice-the same elements are covered in each lesson.
 1. Long tones and articulation practice on the mouthpiece alone and on the instrument. 10 % of the practice time.
 2. Scales, arpeggios and mechanics studies. 20 % of the practice time.
 3. Etudes for developing musical expression and phrasing. 20% of the practice time.
 4. Solo/Chamber repertoire. 25% of the practice time.
 5. Ensemble repertoire. 25 % of the practice time.

17. Advancing Development

More on Air Control

- Mark your breath marks in the music as discussed previously. If you have to practice the music very slowly at first for difficult pieces, mark in very light extra breath marks to erase later as you become more proficient.
- Keep the air going smoothly no matter how much your fingers are moving.
- When blowing a difficult jump or interval, or going over “the break,” focus on “blowing through the difficulty.” “Aim” your air at a note that is a just a bit after the difficult passage so that you won’t “hesitate” at the tough point. Usually it is

not the fingers that are the problem. Your mind sub-consciously is a little afraid of the tough interval and your air pressure “seizes up.”

- Anytime you have trouble with a technical passage, slow it down and blow more air at it. 90% of the time this will clear it up faster than fast practicing.

18. Tongue Position for Higher Pitches on Saxophone

This concept is to counter the poor habit of using more lip pressure on the reed to make higher pitches easier to reach and bring them into tune. Raising the tongue in the oral cavity speeds up the air stream and helps the reed vibrate faster without constricting it and getting a “pinched” sound. Try to have a relaxed free floating sound to your highest notes.

- **Low register:** Say “hawwwwwww” to open your throat all the way and keep the tongue low in the back of the throat. We want a full warm wide column of air to fill the entire clarinet and give a warm, resonant “chalumeau” register.
- **Middle low register:** Say “hhaaaaahhhhh.” This positions the tongue somewhat higher, giving a faster air stream to enrich the throat tones, producing a warm full tone. You still think “ahhhhh” to keep the throat open and flexible.....so it is really haaaww----eeeehhhh.”
- **Middle register:** Say “hhheeeeehhhh.” This positions the back of the tongue high with the back half of it evenly between and pretty much touching your back molars. This increases the air velocity across the arched soft palate and gives a faster air stream into the instrument, producing a brilliant focused sound. Yep, still keep an open throat, by thinking “aawwwww.” **This is the standard tongue position for all registers of bass clarinet.**
- **Middle high register:** Say “hiiiiiihhhhhh.” Now your tongue will should feel like it is between your top teeth.
- **High register:** Say “heeeeeeeee.” Your tongue will be darned close to the roof of your mouth almost all the way to the tip of the tongue. This is for very high notes on most instruments. Baritone saxophonists and bass clarinetists don’t usually need this high a tongue position. **This is the standard tongue position for all registers of the clarinet.**

19. Fingers

- Relax your shoulders, relax your neck. Your head should feel like it is a helium balloon floating above your relaxed shoulder.
- Your arms dangle gently from your relaxed shoulders and your hands dangle gently from your relaxed arms and your fingers dangle gently from your relaxed hands. Shake out your arms, let everything just “fall” from your shoulders.
- Your hands should be shaped as though you are lightly holding an orange.

- For clarinet, your palms should be tilted slightly towards the floor, like you are trying to sneak a peek at your watch when your teacher is not watching. Saxophonists palms should be more vertical and the palms pretty much facing each other.
- Your thumbs should be lined up with your arm, not angled.
- Your right pinky should “default” to the low F (upper C) key on clarinet, low C key on saxophone
- Your left pinky should “default” to the low E (upper B) key on clarinet; g sharp key on saxophone.
- Your right index finger should just about touch the lowest trill key on clarinet, hover over the three right hand side keys on saxophone.
- Your left index fingertip should touch the first “ring” and the A and Ab key.
- Gently, smoothly, stroke the keys. Don’t bang them or attack them. Try and feel the keys smoothly go down and just barely squeeze onto the tone holes. Clarinetists, watch out for “rings” on the pads of your fingers. These are impressed onto your fingers if you are squeezing too hard. You should be able to feel the vibration of your horn in your fingertips.
- Practice very slowly and listen hard for smoothness and evenness and accuracy. Only speed up your metronome when it is perfectly smooth and accurate. Research shows that once you start to repeat a passage, your brain automatically goes into “learning” mood. Your cerebral cortex says, “Oh, you want me to learn that!” So, if you practice too fast and make a few mistakes, your brain engrains those mistakes and you will have trouble changing them back to the right notes.
- You have successfully learned a passage or entire piece of music when you can pick up your horn COLD and play it perfectly at tempo.

20. Instrument Care

a. Sax and Clarinet

- Swab your instrument after each use. Do not pull a swab through your mouthpiece, as the string friction can gradually change the facing or chamber. Use your little finger covered with the silk to clean the mouthpiece. Wash your swab once per month.
- Keep your corks well greased so that the clarinet joints, or saxophone mouthpiece assemble with ease. This also reduces the cork wear and eventual air leaks between the joints.
- Soak your mouthpiece and ligature in a mixture of 50% vinegar, 50% water for 15 minutes once per month. Then clean with cloth over your little finger, and rinse with cool water. This prevents a buildup of calcium that eats away at the most important part of the instrument.

- Always store your instrument in its case. Do not leave it out, as dust will get into the action.
- Never keep any music or accessories in your case contacting the instrument. Reeds, swab and cork grease can go in the space provided in most cases, but that is IT!
- Vacuum your case out once per month. All the little fuzzies and dust in there work their way into your tone holes and your hinge rods.
- Purchase canned compressed air from a camera store to blow dust out from under the rods and keys of your instrument.
- Never lift or assemble your saxophone or clarinet by grasping the keys or rods. Always grasp the body of the clarinet or the bell/thumb rest/neck of the saxophone to prevent bending the keywork.
- Have your instrument fully adjusted by a good repairman at least once per year. A full strip down, cleaning and oiling should be done at least once every two years. A good repairman can also voice your instrument to your taste and adjust the keywork to your hands.

b. Clarinet Only

- Purchase “Goody Ouchless” hair elastics (the ones without any metal on them), and place one over your long B/E key at the top of the lower joint to seal the last two tone holes before putting your clarinet away. This will keep the pads well seated and the clarinet more resonant in tone.
- Put 4 drops of Almond Oil on a swab kept just for this purpose and pull through each joint of your wooden clarinet once every three months. 4 drops for each joint.
- Keep a humistat in wooden clarinet cases. These are little vials that hold water and release moisture through little pores. They keep the humidity high so that the instrument does not go into a dry environment after playing. They have to be filled with water approximately every two weeks. Bass and Alto clarinets or a pair of A and Bb clarinets need two humistats in the case.
- Purchase eye makeup remover without perfume or oils. Purchase a mascara brush. Dip the brush into the fluid and clean out your clarinet tone holes gently once per month. Make sure you also remove the register key and do the register tone hole too. Oils and skin particles from your fingers (and saliva in the register tone hole) collect in these holes and impede air movement, causing intonation and tone problems. In addition they seal off the grain of the wood and eventually lead to cracks in wooden clarinets.

21. The Tone and Articulation Pyramid: a review starting from the foundation up.

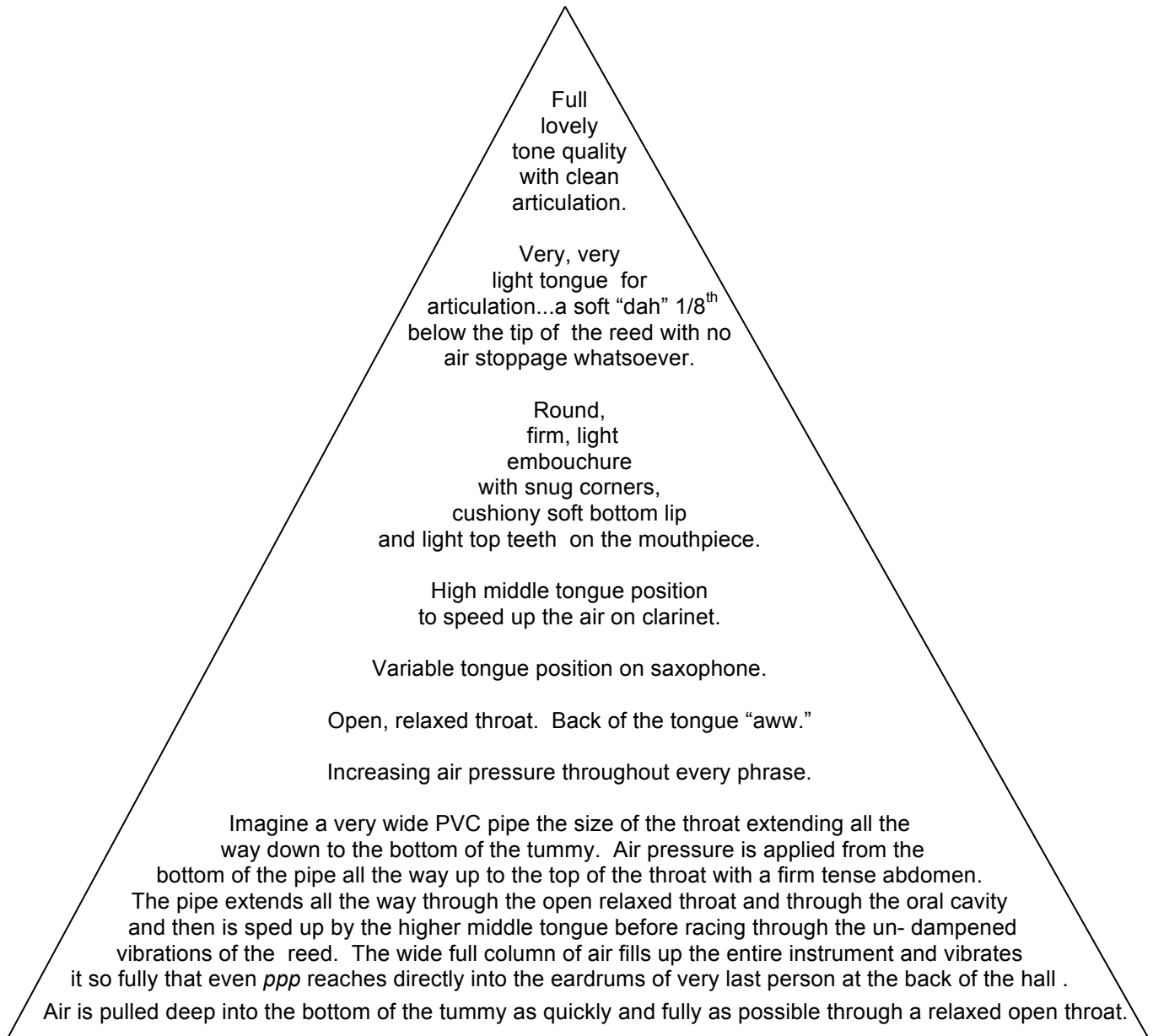

Appendix 1: Mouthpiece Terminology

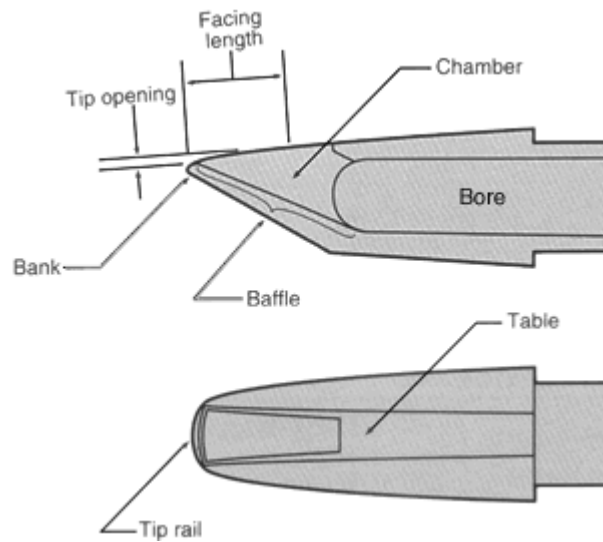

- **Table:** the flat surface upon which the reed is placed.
- **Window:** the hole in the mouthpiece between the tip rail and table.
- **Side rails:** the side edges of the window.
- **Baffle:** the roof of the mouthpiece chamber.

Tip Opening and Facing Length

Wider tip openings and longer facing lengths require softer reeds. Narrower tip openings and shorter facing lengths require harder reeds. Test reed strength by the response and tone quality of the extreme registers of the instrument. Both very high and very low notes need to respond well with good tone quality. Generally speaking classical players use narrower tip openings and shorter facing lengths than jazz or pop players. Current popular classical mouthpieces tend to have medium narrow tip openings with medium long facings to give the player more flexibility in sound and tone colour.

Baffle Height and Chamber Profile

The baffle is the roof of the mouthpiece chamber. A **“high baffle”** is when the baffle is convex: built into the tone chamber, reducing the chamber size and speeding up the air movement into the bore. A high baffle gives a tone with more edge and brightness. Conversely, a **“low baffle”** is less convex or even flat, resulting in a larger chamber and a somewhat darker sound. Generally speaking, classical players use a lower baffle than jazz and pop players.

Bore

Mouthpieces with a small bore give a tighter, more compact, focused sound. They are more individualistic (soloistic) in nature and therefore are better suited for solo playing than for use in ensemble playing. Large bore mouthpieces have a broad and open sound quality and blend well in ensemble situations.

Material

Student mouthpieces are usually made of plastic. They are made to be inexpensive and are molded to precise dimensions for uniformity of specification, but have no hand finishing. They have low baffles, narrow tip openings and short facing lengths for ease of blowing and control while the embouchure develops.

Professional mouthpieces are generally made from Ebonite (hard rubber) or metal, although other materials such as crystal are sometimes used. These mouthpieces last longer, produce a more ringing sound due to the denser material and frequently have hand finishing. They will tend to have wider tip openings and longer facing lengths than student mouthpieces.

Metal mouthpieces tend to vibrate more quickly than ebonite, giving a brighter sound.

Appendix 2 Tempo and Other Markings

Larghissimo-extremely slowly

Largo-broadly

Larghetto-less broadly

Lento-Slow

Grave- heavy, seriously

Adagio-at ease

Adagietto-rather slow

Andante-walking

Andantino-walking with purpose

Moderato

Allegro moderato moderately cheerful and quick

Allegretto-rather lively

Allegro cheerful and quick

Allegro assai "much" cheerful and quick

Vivace "lively"

Vivo "alive"

Presto "soon" very fast

Prestissimo- as fast as possible

Metronomes

Can tempo terms be defined with the metronome?

Most musicians would agree that is not possible to give beats per minute equivalents for these terms: the actual number of beats per minute in a piece marked *allegro*, for example, will depend on the piece of music itself. A piece consisting mainly of half notes can be played much more quickly in terms of BPM than a piece consisting mainly of sixteenth notes but still be described with the same word.

Metronome manufacturers usually do assign beats per minutes values to the traditional terms, but these values are by no means correct for every piece.

Common Qualifiers

- *Assai* – very, very much, as in *Allegro Assai* (but also can mean “enough”)
- *Con brio*- with vigour or spirit
- *Con moto*- with movement
- *Non troppo* – not too much
- *Non tanto* – not so much
- *Molto* – much, very, as in *Molto Allegro* or *Adagio Molto*
- *Poco* – slightly, little, as in *Poco Adagio*
- *Piu* – more, as in *Piu Allegro*; used as a relative indication when the tempo changes
- *Meno* – less, as in *Meno Presto*
- *Poco a poco* – little by little

Mood markings with a tempo connotation

Some markings that primarily mark a mood or character also have a Tempo connotation.

- *Vivace* – lively
- *Maestoso* – majestic or stately
- *Sostenuto* – Sustained, sometimes with a slackening of temp
- *Dolce*- sweetly
- *Morendo* – dying

Terms for change in tempo

Composers may use expressive marks to adjust the tempo:

- *Accelerando* – speeding up (abbreviation: *accel.*)
- *Ritardando* – delaying (abbreviation: *rit. or retard.*)
- *Meno Mosso* – less movement or slower
- *Piu Mosso* – more movement or faster
- *Rallentando* – slowing down, especially near the end of a section (abbreviation: *rall.*)
- *Ritenuto* - slightly slower; temporarily holding back. (Note that the abbreviation for ritardando can also be *rit.* Thus a more specific abbreviation is *riten.*)
- *Stretto* – rushing ahead; temporarily speeding up
- *Stringendo* - Gradually faster. Pressing forward. (Literal translation: tightening)
- *Rubato* – free adjustment of tempo for expressive purposes (literally “robbed,” but you have to give the time back!)

- *Allargando* – growing broader; decreasing it tempo, usually near the end of a piece
- *Mosso* – movement, more lively or quicker
- *Poco a poco* – bit by bit, gradually
- *Subito* – suddenly
- *Poco* – a little
- *Molto* – a lot

French tempo markings

- *Grave* – slowly and solemnly
- *Lent* – slowly
- *Modéré* – moderate
- *Vif* – lively
- *Vite* – fast
- *Tres* – very
- *Moins* – less

German tempo and other markings

- *Langsam* – slowly
- *Mäßig* – moderately
- *Lebhaft* – lively
- *Rasch* – quickly
- *Schnell* - fast
- *sehr langsam und noch zuruckhaltend* - Very slow and with restraint
- *GroBer Ton* - large sound
- *Straffer im Tempo* - Firmly in Tempo
- *stark hervortretend* - strongly prominent
- *FlieBend*- flowing
- *Etwas drangend (unmerklich)*- somewhat forward (imperceptibly)
- *Plotzlich wieder langsam(wie zu anfang) und etwas zogernd* - Suddenly slower again (like the beginning) and somewhat hesitating
- *Ohne Empfindung* - without feeling
- *Ohne Ausdruck* - without expression
- *Immer mit Dampfer* - always with mute
- *Dampfer ab.* - mute off
- *Lang gezogen* - long, drawn out
- *Lang gestrichen* - long bowed
- *Stets breitester Strich!* - always broadest bowing!
- *Wieder altes Tempo* - Again the old tempo
- *Griffbrett* - fingerboard
- *Verklingend*- sounding (audible)

- *Hervortretend* - prominent
- *Stets sehr gehalten* - Always very sustained [restrained]
- *Fließend, doch durchaus nicht eilend* – Flowingly but not hurrying at all
- *Heftig ausbrechend* - violently breaking out
- *Nun etwas drängend* - Now somewhat pushing forward
- *Sehr fließend* - very flowing
- *Schalltrichter auf* – bells up in the air
- *Wieder zurückhaltend* - again restrained
- *Klingen lassen* - let ring
- *Viel bogen* - lots of elbow [bow]
- *get. (getragen)* - sustained
- *Noch breiter als zu Anfang*- still more broadly than the beginning
- *Sehr getragen* - very sustained
- *Ersterbend* - dying away
- *Sehr zart aber ausdrucksvoll* - very tenderly but expressively
- *Espr. gehalten* - expressively restrained
- *Stets ohne Dämpfer* - still without mute
- *Mit inniger Empfindung* – with intimate feeling
- *Zögernd* - hesitating
- *Stets mit Dämpfer* - still with mute
- *Außerst langsam* - Extremely slowly

Copyright © 2007-2014 Chuck Currie, Sax Noir Studio. Unauthorized use and/or duplication of this material without express and written permission from this blog's author and owner is strictly prohibited. Excerpts and links may be used, provided that full and clear credit is given to Chuck Currie and Sax Noir Studio with appropriate and specific direction to the original content.